



**JDV  
CONTROL  
VALVES**

# **JEF / JEG Series**

**Pneumatic Actuator**



# **JMO Series**

**Manual Override**





# JEF / JEG Series Pneumatic Actuator



JEF/JEG series pneumatic actuators are specifically designed to respond to your demanding needs on automation valve market. We can provide a wide range of torque outputs to suit quarter turn ball, butterfly, plug valves and dampers for complete valve automation solutions. The latest manufacturing technologies have been operated in order to supply a high quality and cycle-life on JEF/JEG series. Our extensive inventory & engineering capabilities allow us to provide reliable and safety products to our customer with satisfaction.

JEF/JEG 系列气动执行器是专为球阀、蝶阀、旋塞阀、风门等 1/4 转阀门运用在制程上控制而设计出的理想产品。双齿轮齿排设计再加上曲柄式设计，提供使用者更多选择以应不同的工况要求。优越的结构设计、精密的加工制程、强化的表面特殊处理以及严格的品质控管过程，使产品不仅达到最佳的控制性能，亦增加其使用寿命。

## PRODUCT FEATURES 产品特色

	Standard Version
Type	Twin Rack & Pinion Design: - Double Acting: JEF-040~210 - Spring Return: JEG-050~210 Scotch Yoke Design: - Double Acting: JEF-230~290 - Spring Return: JEG-230~290
Specification	Interface Actuator/Valve: 4 or 8 female thread holes in the body conforms to DIN/ISO 5211, PART 1+2 Shaft: DIN 3337 Interface Actuator/Solenoid Valve: NAMUR Interface Actuator/Signal Unit: NAMUR
Ambient Temperature	Standard: -20 ~ 80 Deg C Option: -20 ~ 150 Deg C -35 ~ 80 Deg C
Torque Range	4 ~ 5000 Nm

	Standard Version
Material	Body: - Standard Aluminum Alloy + Hard Anodized - Option: Aluminum Alloy + Epoxy Coated End Caps: Aluminum Alloy + Epoxy Coated Pinion Shaft: Alloy Steel + Electroless Nickel Plated Piston: Diecasted Aluminum Piston Seals: - Standard NBR Rubber - Option: Viton for higher or lower temperature Piston Guide: Self-lubricating Polypropylene + GF Springs: Alloy Steel
Air Supply	2.5 ~ 8.0 Bar
Movement	91.5° From -0.5° CW to 91° CCW
Medium Quality	Filtered air (Residual oil, sust, and water mediums) according to PNEURO/ISO Class 4

## JEF DOUBLE ACTING 双动系列

JEF-040~210



JEF-230/290

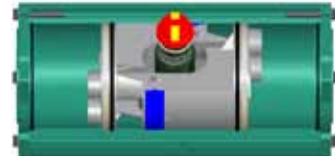

## JEG SINGLE ACTING 单动系列

JEG-050~210

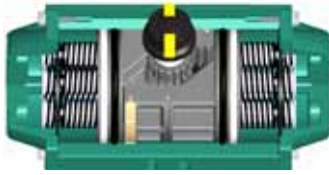

JEG-230/290

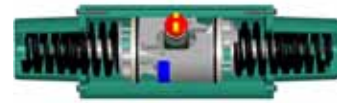

## Technical Specification 技术资料

### JEF-040

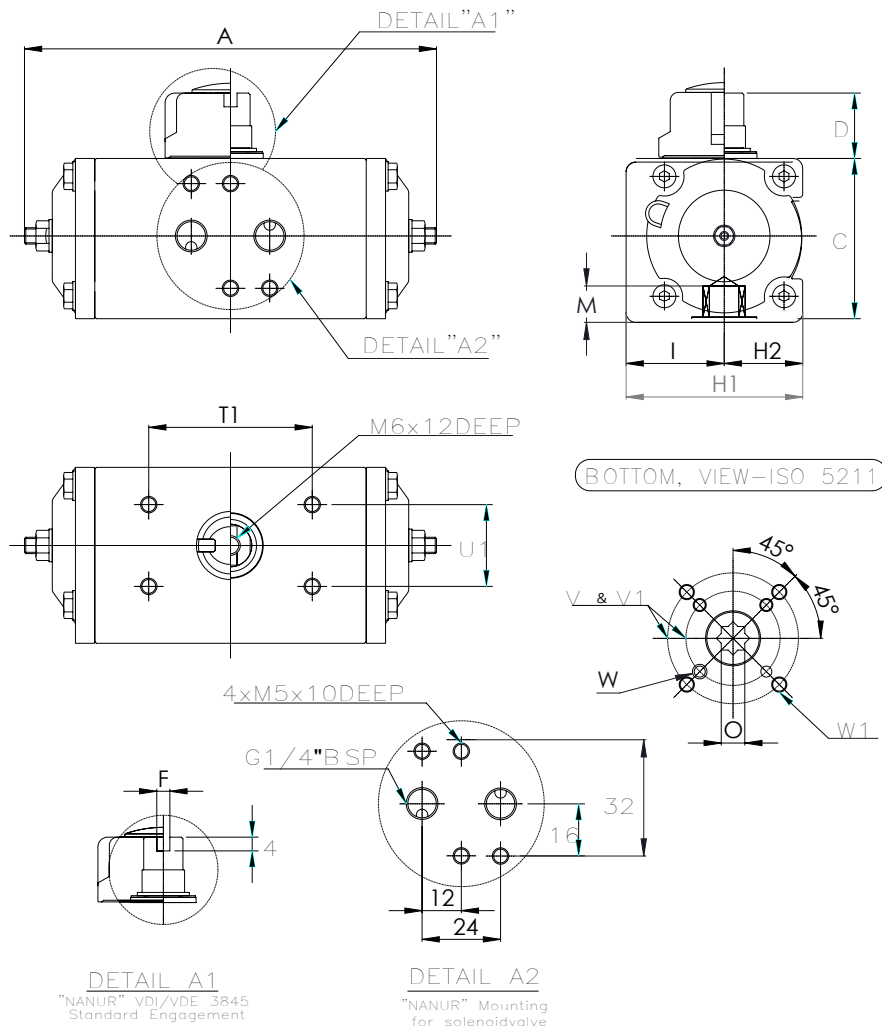

### DIMENSION

(M.M)

TYPE	A	C	D	F	H1	H2	I	M	O	T1	U1	V1/V	W/W1	ISO 5211
JEF-040	126	49	20	4	54	24	30	10	9	50	25	∅ 36/∅ 50	M5/M6	F03/F05



**JDV  
CONTROL  
VALVES**

## JEF/JEG-050 ~ 210

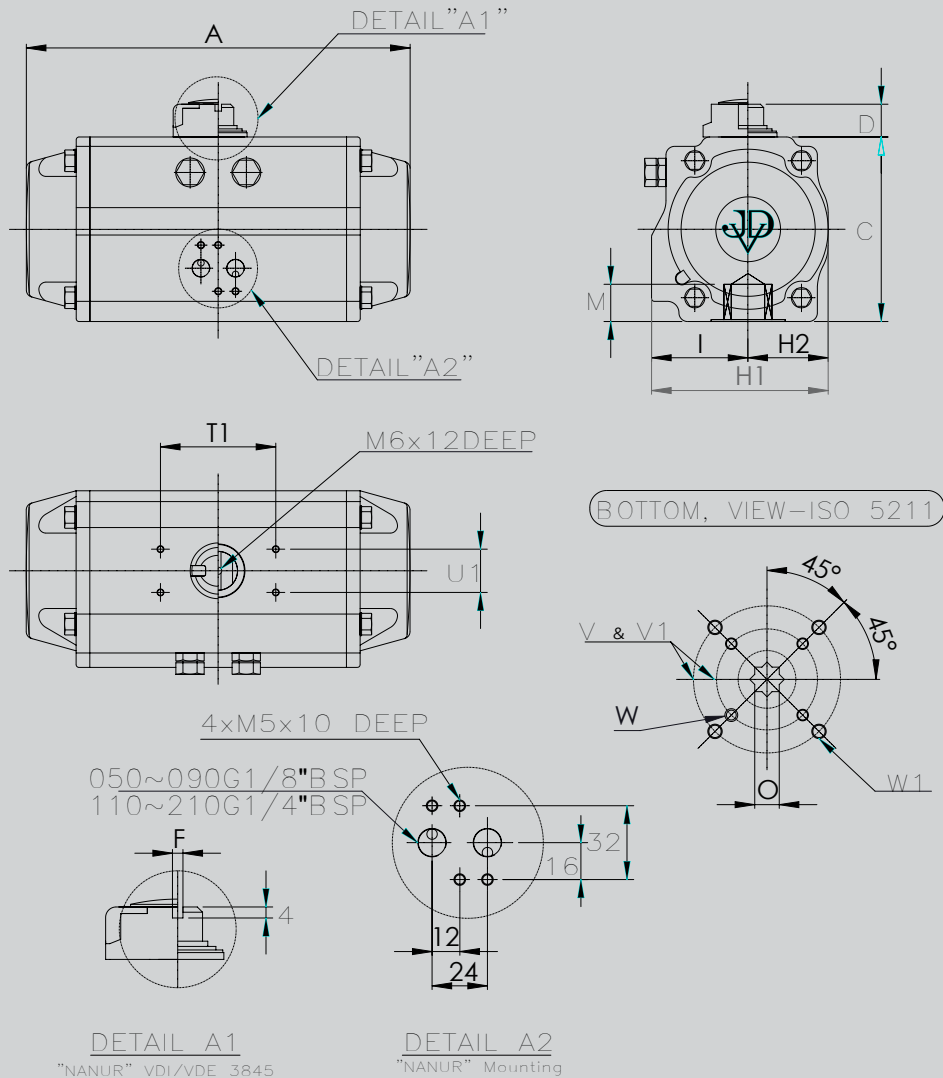

### DIMENSION

(M.M)

TYPE	A	C	D	F	H1	H2	I	M	O	T1	U1	V	W	ISO 5211
JEF/JEG-050	144	73	20	4	72	30	42	14	11	80	30	∅ 36/ ∅ 50	M5/M6	F03/F05
JEF/JEG-060	163	87	20	4	85	38	47	18	14	80	30	∅ 50/ ∅ 70	M6/M8	F05/F07
JEF/JEG-070	202	87	20	4	85	38	47	18	14	80	30	∅ 50/ ∅ 70	M6/M8	F05/F07
JEF/JEG-080	210	104	20	4	96	42.5	53.5	22	17	80	30	∅ 50/ ∅ 70	M6/M8	F05/F07
JEF/JEG-090	247	116	20	4	108	49.5	58.5	22	17	80	30	∅ 50/ ∅ 70/ ∅ 102	M6/M8/M10	F05/F07/ F10
JEF/JEG-100	268	128	20	4	123	56	67	22	17	80	30	∅ 50/ ∅ 70/ ∅ 102	M8/M10	F05/F07/ F10
JEF/JEG-110	316	146	20	4	141	64	77	32	22	80	30	∅ 70/ ∅ 102	M8/M10	F07/F10
JEF/JEG-120	347	159	20	4	151	69	82	32	22	80	30	∅ 70/ ∅ 102/ ∅ 125	M8/M10/M12	F07/F10/ F12
JEF/JEG-130	414	179	30	4	172	80	92	36	27	80	30	∅ 102/ ∅ 125	M10/M12	F10/F12
JEF/JEG-140	467	196	30	4	190	89	101	36	27	130	30	∅ 102/ ∅ 125	M10/M12	F10/F12
JEF/JEG-150	497	221	30	4	206	99	107	39	36	130	30	∅ 102/ ∅ 125	M10/M12	F10/F12
JEF/JEG-160	555	247	30	4	227	111	116	39	36	130	30	∅ 140	M16	F14
JEF/JEG-170	628	256	30	4	236	116	120	43	36	130	30	∅ 140	M16	F14

## JEF/JEG-230

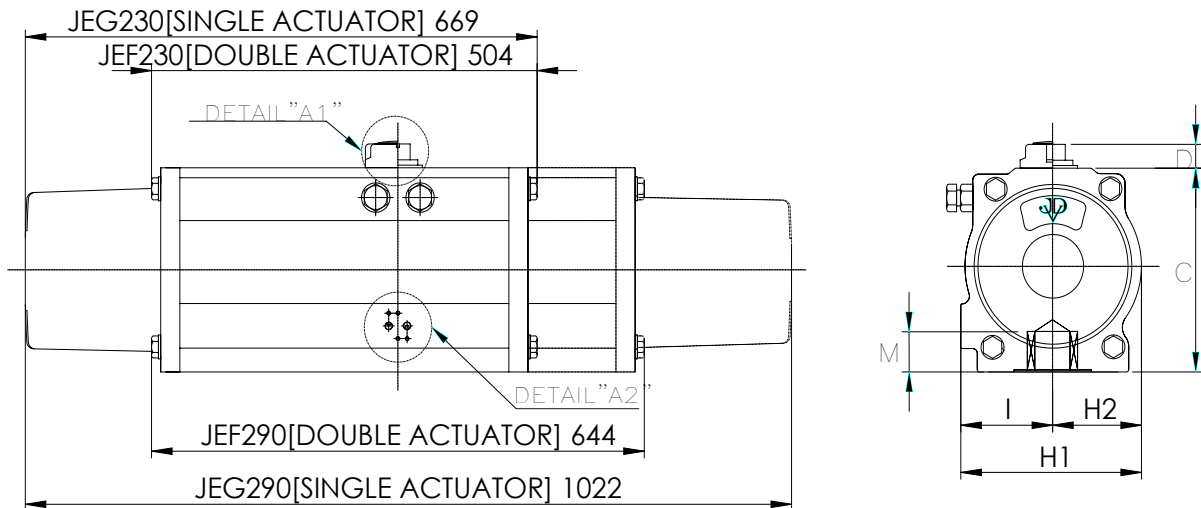

## JEF/JEG-290

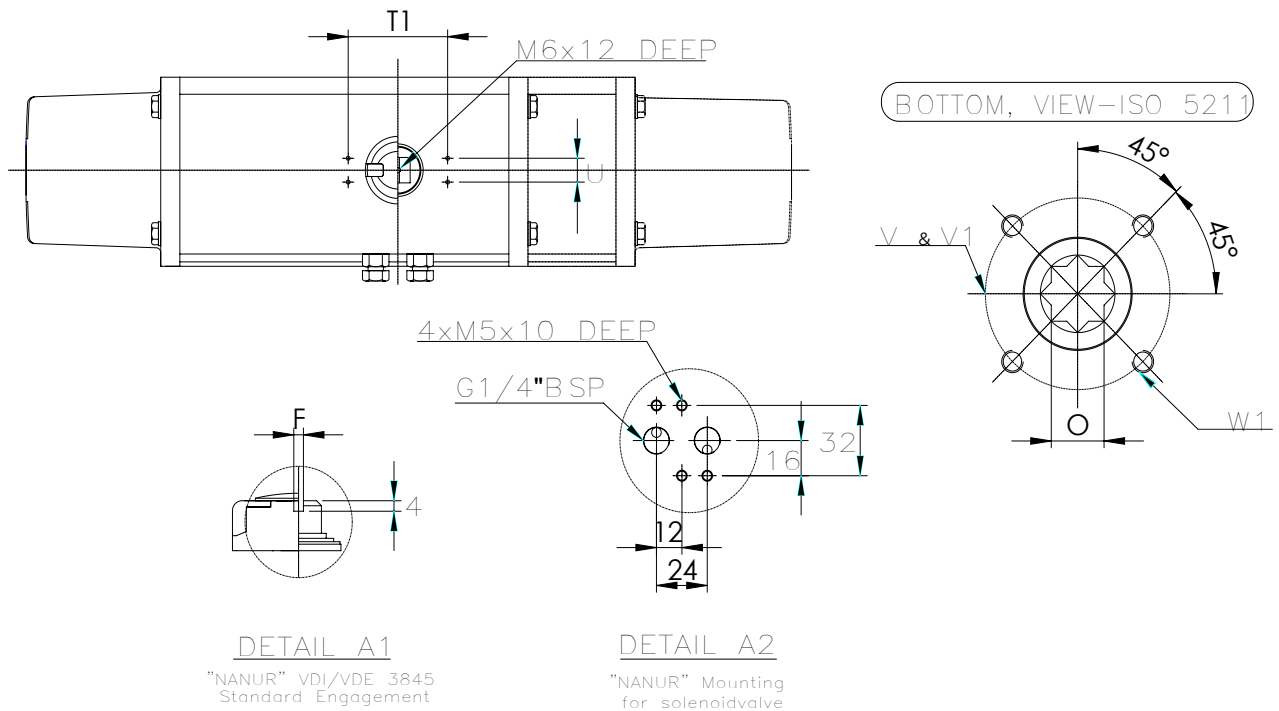

### DIMENSION

(M.M)

TYPE	A	C	D	F	H1	H2	I	M	O	T1	U1	V1/V	W/W1	ISO 5211
JEF/JEG-290		256	30	4	236	116	120	54	46	130	30	∅ 160	M16	F16
JEF/JEG-290		256	30	4	236	116	120	54	46	130	30	∅ 160	M16	F16



## WEIGHT 重量表

JEF	KG/EA	JEF	KG/EA
040	0.54	130	11.30
050	1.16	140	14.10
060	1.68	160	22.00
070	2.40	180	26.50
080	3.00	200	38.40
090	4.30	210	46.00
110	6.00	230	46.00
120	9.00	290	71.00

SPRING	KG/EA	SPRING	KG/EA
040		130	0.165
050	0.009	140	0.202
060	0.017	160	0.359
070	0.021	180	0.521
080	0.033	200	0.752
090	0.056	210	0.882
110	0.078	230	14.1
120	0.121	290	28.2

JEG WEIGHT = JEF + SPRINGS

## AIR CONSUMPTION 空气消耗量

DOUBLE ACTING											
MODEL	VOLUME	2.5 Bar	3 Bar	3.5 Bar	4 Bar	4.5 Bar	5 Bar	5.5 Bar	6 Bar	7 Bar	8 Bar
JEF-040	0.20	0.70	0.80	0.90	1.00	1.10	1.20	1.30	1.40	1.60	1.80
JEF-050	0.30	1.10	1.20	1.40	1.50	1.70	1.80	2.00	2.10	2.40	2.70
JEF-060	0.50	1.80	2.00	2.30	2.50	2.80	3.00	3.30	3.60	4.10	4.60
JEF-070	0.50	1.80	2.00	2.30	2.50	2.80	3.00	3.30	3.60	4.10	4.60
JEF-080	0.80	2.80	3.20	3.70	4.10	4.50	4.90	5.30	5.70	6.50	7.30
JEF-090	1.30	4.60	5.30	5.90	6.60	7.30	7.90	8.60	9.30	10.60	11.90
JEF-110	1.80	6.40	7.30	8.20	9.10	10.10	11.00	11.90	12.80	14.60	16.50
JEF-120	3.00	10.60	12.20	13.70	15.20	16.80	18.30	19.80	21.40	24.40	27.50
JEF-130	3.80	13.50	15.40	17.40	19.30	21.20	23.30	25.10	27.00	30.90	34.80
JEF-140	6.20	22.00	25.20	28.30	31.50	34.60	37.80	41.00	44.10	50.50	56.80
JEF-160	7.30	25.90	29.60	33.40	37.10	40.80	44.50	48.20	52.00	59.40	66.90
JEF-180	11.20	39.80	45.50	51.20	56.90	62.60	68.30	74.00	79.70	91.10	102.60
JEF-200	15.40	54.70	62.50	70.40	78.20	86.10	93.90	101.80	109.60	125.30	141.00
JEF-210	23.80	84.50	96.60	108.70	120.90	133.00	145.10	157.30	169.40	193.70	218.00
JEF-230	19.10	67.80	77.50	87.30	97.00	106.70	116.50	126.20	136.00	155.40	174.90
JEF-290	29.60	105.10	120.10	135.20	150.30	165.40	180.50	195.60	210.70	240.90	271.10

SPRING ACTING											
MODEL	VOLUME	2.5 Bar	3 Bar	3.5 Bar	4 Bar	4.5 Bar	5 Bar	5.5 Bar	6 Bar	7 Bar	8 Bar
JEG-050	0.10	0.40	0.40	0.50	0.50	0.60	0.60	0.70	0.70	0.80	0.90
JEG-060	0.20	0.70	0.80	0.90	1.00	1.10	1.20	1.30	1.40	1.60	1.80
JEG-070	0.20	0.70	0.80	0.90	1.00	1.10	1.20	1.30	1.40	1.60	1.80
JEG-080	0.30	1.10	1.20	1.40	1.50	1.70	1.80	2.00	2.10	2.40	2.70
JEG-090	0.50	1.80	2.00	2.30	2.50	2.80	3.00	3.30	3.60	4.10	4.60
JEG-110	0.70	2.50	2.80	3.20	3.60	3.90	4.30	4.60	5.00	5.70	6.40
JEG-120	1.20	4.30	4.90	5.50	6.10	6.70	7.30	7.90	8.50	9.80	11.00
JEG-130	1.50	5.30	6.10	6.90	7.60	8.40	9.10	9.90	10.70	12.20	13.70
JEG-140	2.40	8.50	9.70	11.00	12.20	13.40	14.60	15.90	17.10	19.50	22.00
JEG-160	3.10	11.00	12.60	14.20	15.70	17.30	18.90	20.50	22.10	25.20	28.40
JEG-180	4.30	15.30	17.50	19.60	21.80	24.00	26.20	28.40	30.60	35.00	39.40
JEG-200	5.90	20.90	23.90	27.00	30.00	33.00	36.00	39.00	42.00	48.00	54.00
JEG-210	7.80	27.70	31.70	35.60	39.60	43.60	47.60	51.50	55.50	63.50	71.40
JEG-230	5.10	18.10	20.70	23.30	25.90	28.50	31.10	33.70	36.30	41.50	46.70
JEG-290	9.60	34.10	39.00	43.90	48.80	53.70	58.50	63.40	68.30	78.10	87.90



**DOUBLE ACTING TORQUE SHEET- JEF SERIES 双动扭力表**

(Nm)

Type	Operating pressure P St [bar]									
	2.5	3	3.5	4	4.5	5	5.5	6	7	8
JEF-040	3.8	4.5	5.3	6	6.8	7.5	8.3	9	10.5	12
JEF-050	8.3	10	11.7	13.3	15	16.6	18.3	20	23.3	26.6
JEF-060	15	17.9	20.9	23.9	26.9	29.9	32.9	35.9	41.9	47
JEF-070	20.9	25.1	29.3	33.5	37.7	41.9	46.1	50.3	58.6	67
JEF-080	28.7	34.5	40.2	45.9	51.7	57.4	63.2	68.9	80.4	92
JEF-090	46.1	55.3	64.5	73.7	83	92.2	101	111	129	147
JEF-110	68.2	81.9	95.5	109	123	137	150	164	191	214
JEF-120	108	129	151	172	194	215	237	258	301	344
JEF-130	139	166	194	222	249	277	305	333	388	443
JEF-140	218	261	305	348	392	435	479	522	609	696
JEF-160	284	341	397	454	511	567	624	681	794	908
JEF-180	383	460	536	613	689	766	842	919	1072	1225
JEF-200	532	638	744	851	957	1063	1170	1276	1489	1702
JEF-210	587	704	822	939	1056	1174	1291	1409	1643	1878

JEF-230	Start	Run	End
4.2Bar	1507	753	1312
5.6Bar	2009	1005	1750
7 Bar	2511	1255	2187

JEF-290	Start	Run	End
4.2Bar	3011	1506	2622
5.6Bar	4017	2006	3498
7 Bar	5022	2509	4373

1 Nm = 8.86 Lb-in    1 Lb-in = 0.0115 Kgm    1 Kgm = 9.81 Nm    1 Mpa = 10 Bar  
 1 Lb-in = 0.113 Nm    1 Bar = 14.5 Psi    1 Kgm = 86.8 Lb-in    1 Lb-ft = 12 Lb-in





**JDV  
CONTROL  
VALVES**

**SPRING ACTING TORQUE SHEET- JEG SERIES 单动扭力表**

(Nm)

Type	Spring strength MdF[NM]		Usable pneumatic torque MdN at minimum operating pressure P St min [bar]																				
			2.5		3		3.5		4		4.5		5		5.5		6		7		8		
Nos. of springs	90	0	0	90	0	90	0	90	0	90	0	90	0	90	0	90	0	90	0	90	0	90	
JEG-050-05	4.9	3.4	4.9	3.4	6.6	5.1	8.3	6.8	9.9	8.4	11.6	10.1	13.2	11.7	14.9	13.4							
- Set 06	5.8	4	4.3	2.5	6	4.2	7.7	5.9	9.3	7.5	11	9.2	12.6	10.8	14.3	12.5	16	14.2					
- Set 07	6.8	4.7	3.6	1.5	5.3	3.2	7	4.9	8.6	6.5	10.3	8.2	11.9	9.8	13.6	11.5	15.3	13.2	18.6	16.5			
- Set 08	7.8	5.4			4.6	2.2	6.3	3.9	7.9	5.5	9.6	7.2	11.2	8.8	12.9	10.5	14.6	12.2	17.9	15.5			
- Set 09	8.8	6.1					5.6	2.9	7.2	4.5	8.9	6.2	10.5	7.8	12.2	9.5	13.9	11.2	17.2	14.5	20.5	17.8	
- Set 10	9.7	6.7							6.6	3.6	8.3	5.3	9.9	6.9	11.6	8.6	13.3	10.3	16.6	13.6	19.9	16.9	
- Set 11	10.7	7.4									7.6	4.3	9.2	5.9	10.9	7.6	12.6	9.3	15.9	12.6	19.2	15.9	
- Set 12	11.7	8.1													10.2	6.6	11.9	8.3	15.2	11.6	18.5	14.9	
JEG-060-05	8.4	5.5	9.5	6.6	12.4	9.5	15.4	12.5	18.4	15.5	21.4	18.5	24.4	21.5	27.4	24.5							
- Set 06	10.1	6.7	8.3	4.9	11.2	7.8	14.2	10.8	17.2	13.8	20.2	16.8	23.2	19.8	26.2	22.8	29.2	25.8					
- Set 07	11.8	7.8	7.2	3.2	10.1	6.1	13.1	9.1	16.1	12.1	19.1	15.1	22.1	18.1	25.1	21.1	28.1	24.1	34.1	30.1			
- Set 08	13.5	8.9			9	4.4	12	7.4	15	10.4	18	13.4	21	16.4	24	19.4	27	22.4	33	28.4			
- Set 09	15.2	10					10.9	5.7	13.9	8.7	16.9	11.7	19.9	14.7	22.9	17.7	25.9	20.7	31.9	26.7	37	31.8	
- Set 10	16.9	11.1							12.8	7	15.8	10	18.8	13	21.8	16	24.8	19	30.8	25	35.9	30.1	
- Set 11	18.6	12.2									14.7	8.3	17.7	11.3	20.7	14.3	23.7	17.3	29.7	23.3	34.8	28.4	
- Set 12	20.2	13.3													19.6	12.7	22.6	15.7	28.6	21.7	33.7	26.8	
JEG-070-05	12	7.6	13.3	8.9	17.5	13.1	21.7	17.3	25.9	21.5	30.1	25.7	34.3	29.9	38.5	34.1							
- Set 06	14.4	9.1	11.8	6.5	16	10.7	20.2	14.9	24.4	19.1	28.6	23.3	32.8	27.5	37	31.7	41.2	35.9					
- Set 07	16.8	10.6			14.5	8.3	18.7	12.5	22.9	16.7	27.1	20.9	31.3	25.1	35.5	29.3	39.7	33.5	48	41.8			
- Set 08	19.2	12.1			13	5.9	17.2	10.1	21.4	14.3	25.6	18.5	29.8	22.7	34	26.9	38.2	31.1	46.5	39.4			
- Set 09	21.6	13.7					15.6	7.7	19.8	11.9	24	16.1	28.2	20.3	32.4	24.5	36.6	28.7	44.9	37	53.3	45.4	
- Set 10	24	15.2							18.3	9.5	22.5	13.7	26.7	17.9	30.9	22.1	35.1	26.3	43.4	34.6	51.8	43	
- Set 11	26.4	16.7									21	11.3	25.2	15.5	29.4	19.7	33.6	23.9	41.9	32.2	50.3	40.6	
- Set 12	28.8	18.2													27.9	17.3	32.1	21.5	40.4	29.8	48.8	38.2	
JEG-080-05	17.3	11.1	17.6	11.4	23.4	17.2	29.1	22.9	34.8	28.6	40.6	34.4	46.3	40.1	52.1	45.9							
- Set 06	20.8	13.3	15.4	7.9	21.2	13.7	26.9	19.4	32.6	25.1	38.4	30.9	44.1	36.6	49.9	42.4	55.6	48.1					
- Set 07	24.2	15.5	13.2	4.5	19	10.3	24.7	16	30.4	21.7	36.2	27.5	41.9	33.2	47.7	39	53.4	44.7	64.9	56.2			
- Set 08	27.7	17.7			16.8	6.8	22.5	12.5	28.2	18.2	34	24	39.7	29.7	45.5	35.5	51.2	41.2	62.7	52.7			
- Set 09	31.2	19.9					20.3	9	26	14.7	31.8	20.5	37.5	26.2	43.3	32	49	37.7	60.5	49.2	72.1	60.8	
- Set 10	34.6	22.1							23.8	11.3	29.6	17.1	35.3	22.8	41.1	28.6	46.8	34.3	58.3	45.8	69.9	57.4	
- Set 11	38.1	24.3									27.4	13.6	33.1	19.3	38.9	25.1	44.6	30.8	56.1	42.3	67.7	53.9	
- Set 12	41.5	26.5													36.7	21.7	42.4	27.4	53.9	38.9	65.5	50.5	
JEG-090-05	28.9	18.3	27.8	17.2	37	26.4	46.2	35.6	55.4	44.8	64.7	54.1	73.9	63.3	83.1	72.5							
- Set 06	34.7	22	24.1	11.4	33.3	20.6	42.5	29.8	51.7	39	61	48.3	70.2	57.5	79.4	66.7	88.6	75.9					
- Set 07	40.4	25.7	20.4	5.7	29.6	14.9	38.8	24.1	48	33.3	57.3	42.6	66.5	51.8	75.7	61	84.9	70.2	103	88.6			
- Set 08	46.2	29.3			26	9.1	35.2	18.3	44.4	27.5	53.7	36.8	62.9	46	72.1	55.2	81.3	64.4	99.7	82.8			
- Set 09	52	33					31.5	12.5	40.7	21.7	50	31	59.2	40.2	68.4	49.4	77.6	58.6	96	77	114	95	
- Set 10	57.8	36.7							37	15.9	46.3	25.2	55.5	34.4	64.7	43.6	73.9	52.8	92.3	71.2	110	89.2	
- Set 11	63.5	40.3									42.7	19.5	51.9	28.7	61.1	37.9	70.3	47.1	88.7	65.5	107	83.5	
- Set 12	69.3	44													57.4	32.1	66.6	41.3	85	59.7	103	77.7	
JEG-110-05	39.4	25.3	42.9	28.8	56.6	42.5	70.2	56.1	83.9	69.8	97.5	83.4	111	97.1	125	111							
- Set 06	47.3	30.4	37.8	20.9	51.5	34.6	65.1	48.2	78.8	61.9	92.4	75.5	106	89.2	120	103	133	117					
- Set 07	55.1	35.5	32.7	13.1	46.4	26.8	60	40.4	73.7	54.1	87.3	67.7	101	81.4	115	95	128	109	156	136			
- Set 08	63	40.5			41.4	18.9	55	32.5	68.7	46.2	82.3	59.8	96	73.5	110	87.1	123	101	151	128			
- Set 09	70.9	45.6					49.9	24.6	63.6	38.3	77.2	51.9	90.9	65.6	104.5	79.2	118	92.9	146	120	168	143	
- Set 10	78.8	50.7							58.5	30.4	72.1	44	85.8	57.7	99.4	71.3	113	85	140	112	163	135	
- Set 11	86.7	55.7									67.1	36.1	80.8	49.8	94.4	63.4	108	77.1	135	104	158	127	
- Set 12	94.5	60.8													89.3	55.6	103	69.3	130	96.6	153	120	
JEG-120-05	65.5	41	66.5	42	88	63.5	110	85	131	107	153	128	174	150	196	171							
- Set 06	78.6	49.2	58.3	28.9	79.8	50.4	101	71.9	123	93.4	144	115	166	136	187	158	209	179					
- Set 07	91.7	57.4	50.1	15.8	71.6	37.3	93.1	58.8	115	80.3	136	102	158	123	179	145	201	166	244	209			
- Set 08	105	65.6			63.4	24	84.9	45.5	106	67	128	88.5	149	110	171	132	192	153	235	196			



Type	Spring strength MdF[NM]		Usable pneumatic torque MdN at minimum operating pressure P St min [bar]																			
			2.5		3		3.5		4		4.5		5		5.5		6		7		8	
Nos. of springs	90	0	0	90	0	90	0	90	0	90	0	90	0	90	0	90	0	90	0	90	0	90
- Set 09	118	73.8					76.7	32.5	98.2	54	120	75.5	141	97	163	119	184	140	227	183	270	226
- Set 10	131	82							90	41	112	62.5	133	84	155	106	176	127	219	170	262	213
- Set 11	144	90.2									103	49.5	125	71	146	92.5	168	114	211	157	254	200
- Set 12	157	98.4													138	79.5	160	101	203	144	246	187
JEG-130-05	82	52.5	86	56.5	114	84.2	142	112	169	140	197	167	225	195	252	223						
- Set 06	99	63	75.5	39.5	103	67.2	131	95	159	123	186	150	214	178	242	206	270	234				
- Set 07	115	73.5	65	23.5	92.7	51.2	121	79	148	107	176	134	204	162	231	190	259	218	314	273		
- Set 08	132	84			82.2	34.2	110	62	138	89.7	165	117	193	145	221	173	249	201	304	256		
- Set 09	148	94.5					99.5	46	127	73.7	155	101	183	129	210	157	238	185	293	240	349	295
- Set 10	165	105							117	56.7	144	84.4	172	112	200	140	228	168	283	223	338	278
- Set 11	181	116									133	68.4	161	96.1	189	124	217	152	272	207	327	262
- Set 12	198	126													179	107	207	135	262	190	317	245
JEG-140-05	129	82	136	88.5	136	88.5	223	176	266	219	310	263	353	306	397	350						
- Set 06	155	99	119	62.5	119	62.5	206	150	249	193	293	237	336	280	380	324	423	367				
- Set 07	180	115	103	37.5	103	37.5	190	125	233	168	277	212	320	255	364	299	407	342	494	429		
- Set 08	206	132			85.5	11.5	173	98.5	216	142	260	186	303	229	347	273	390	316	477	403		
- Set 09	232	148					157	72.5	200	116	244	160	287	203	331	247	374	290	461	377	548	464
- Set 10	258	165							183	90	227	134	270	177	314	221	357	264	444	351	531	438
- Set 11	283	181									211	109	254	152	298	196	341	239	428	326	515	413
- Set 12	309	198													281	170	324	213	411	300	498	387
JEG-160-05	166	112	172	118	229	175	285	231	342	288	399	345	455	401	512	458						
- Set 06	199	135	149	84.7	206	142	262	198	319	255	376	312	432	368	489	425	546	482				
- Set 07	233	157	127	50.7	184	108	240	164	297	221	354	278	410	334	467	391	524	448	637	561		
- Set 08	266	180			161	74.5	217	131	274	188	331	245	387	301	444	358	501	415	614	528		
- Set 09	299	202					195	98.2	252	155	309	212	365	268	422	325	479	382	592	495	706	609
- Set 10	332	224							230	122	287	179	343	235	400	292	457	349	570	462	684	576
- Set 11	365	247									264	146	320	202	377	259	434	316	547	429	661	543
- Set 12	399	269													355	225	412	282	525	395	639	509
JEG-180-05	237	158	225	146	301	222	378	299	455	376	531	452	608	529	684	605						
- Set 06	284	190	193	98.8	269	175	346	252	423	329	499	405	576	482	652	558	729	635				
- Set 07	332	221	162	50.8	238	127	315	204	392	281	468	357	545	434	621	510	698	587	851	740		
- Set 08	379	253			206	80.4	283	157	360	234	436	310	513	387	589	463	666	540	819	693		
- Set 09	426	285					251	110	328	187	404	263	481	340	557	416	634	493	787	646	940	799
- Set 10	474	316							297	139	373	215	450	292	526	368	603	445	756	598	909	751
- Set 11	521	348									341	168	418	245	494	321	571	398	724	551	877	704
- Set 12	568	379													463	274	540	351	693	504	846	657
JEG-200-05	315	213	319	217	425	323	531	429	638	536	744	642	850	748	957	855						
- Set 06	378	255	277	154	383	260	489	366	596	473	702	579	808	685	915	792	1021	898				
- Set 07	441	298	234	90.7	340	197	446	303	553	410	659	516	765	622	872	729	978	835	1191	1048		
- Set 08	504	340			298	134	404	240	511	347	617	453	723	559	830	666	936	772	1149	985		
- Set 09	567	383					361	177	468	284	574	390	680	496	787	603	893	709	1106	922	1319	1135
- Set 10	630	425							426	221	632	327	638	433	745	540	851	646	1064	859	1277	1072
- Set 11	693	468									489	264	595	370	702	477	808	583	1021	796	1234	1009
- Set 12	756	510													660	414	766	520	979	733	1192	946
JEG-210-04	274	157	430	313	547	430	665	547	782	665												
- Set 05	343	196	391	244	508	362	626	479	743	596	860	714	978	831	1095	948						
- Set 06	411	235	352	176	469	293	586	410	704	528	821	645	939	762	1056	880	1173	997				
- Set 07	480	275			430	224	547	342	664	459	782	576	899	694	1017	811	1134	929	1369	1163		
- Set 08	549	314					508	273	625	391	743	508	860	625	977	743	1095	860	1330	1095		
- Set 09	617	353					469	205	586	322	703	439	821	557	938	674	1056	791	1290	1026	1525	1261
- Set 10	686	392					429	136	547	253	664	371	782	488	899	606	1016	723	1251	958	1486	1192
- Set 11	754	431									625	302	742	420	860	537	977	654	1212	889	1447	1124
- Set 12	823	471									586	234	703	351	821	468	938	586	1173	821	1407	1055

JEG-230	AIR TORQUE			SPRING TORQUE		
	Start	Run	End	Start	Run	End
4.2Bar	1,114	452	634	678	283	393
5.6Bar	1,385	537	724	1,026	446	624

JEG-290	AIR TORQUE			SPRING TORQUE		
	Start	Run	End	Start	Run	End
4.2Bar	2,226	904	1,266	1,356	565	780
5.6Bar	2,769	1,074	1,446	2,045	883	1,243



FOR JEF/JEG-040 ~ 210

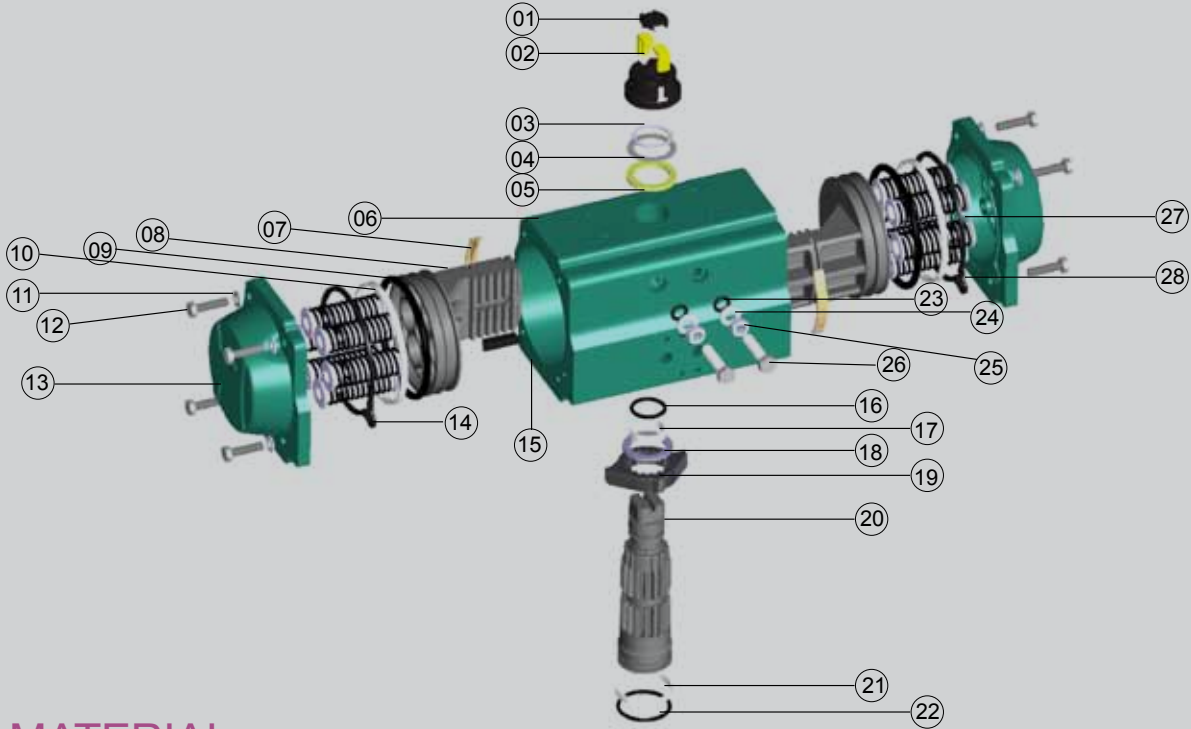

**MATERIAL**

NO	PART DESCRIPTION	UNIT Q'TY	MATERIAL	CORROSION PROTECTION	OPTIONAL MATERIAL
1	Position indicator	4	Polypropylene+GF		
2	Position indicator holder	1	Polypropylene+GF		
3	Spring clip (pinion)	1	Stainless Steel	HP160,200Nickel plated	
4	Thrust washer (pinion)	1	Stainless Steel		
5	Thrust bearing (pinion)	1	Polyphthalamide		
6	Body	1	Extruded Aluminium alloy	Hard anodized	
7	Bearing (piston back)	2	Polyphthalamide		
8	Piston	2	Die Cast Aluminium	Hard anodized	
9	O Ring (piston)	2	Nitrile (NBR70)		Viton SiliconViton
10	Bearing (piston head)	2	Polyphthalamide		
11	Cap bolt washer	8	Stainless Steel		
12	Cap bolt (end cap)	2	Stainless Steel		
13	Right and left end cap	2	Die Cast Aluminium	Chromate+Polyester coated	
14	O Ring (end cap)	2	Nitrile (NBR70)		Viton SiliconViton
15	Piston guide	1	Polypropylene+GF		
16	O Ring (pinion top)	1	Nitrile (NBR70)		Viton SiliconViton
17	Bearing (pinion top)	1	Nylon 46		
18	Thrust bearing (pinion)	1	Polyphthalamide		
19	Open.Close cam(stop arrangement)	1	Stainless Steel		
20	Drive shaft	1	Steel alloy	Nickel planted	
21	Bearing(piston bottom)	1	Nylon 46		
22	O Ring (pinion bottom)	1	Nitrile (NBR70)		Viton SiliconViton
23	O Ring (stop screw)	1	Nitrile (NBR70)		Viton SiliconViton
24	Stop bolt washer	2	Stainless Steel		
25	Stop nut	2	Stainless Steel		
26	Stop bolt	2	Stainless Steel		
27	Spring (catridge)	min.5/max.12	High alloy Spring Steel	Epoxy coated	
28	Spring holder	1	Polypropylene+GF		

FOR JEF/JEG-230~290

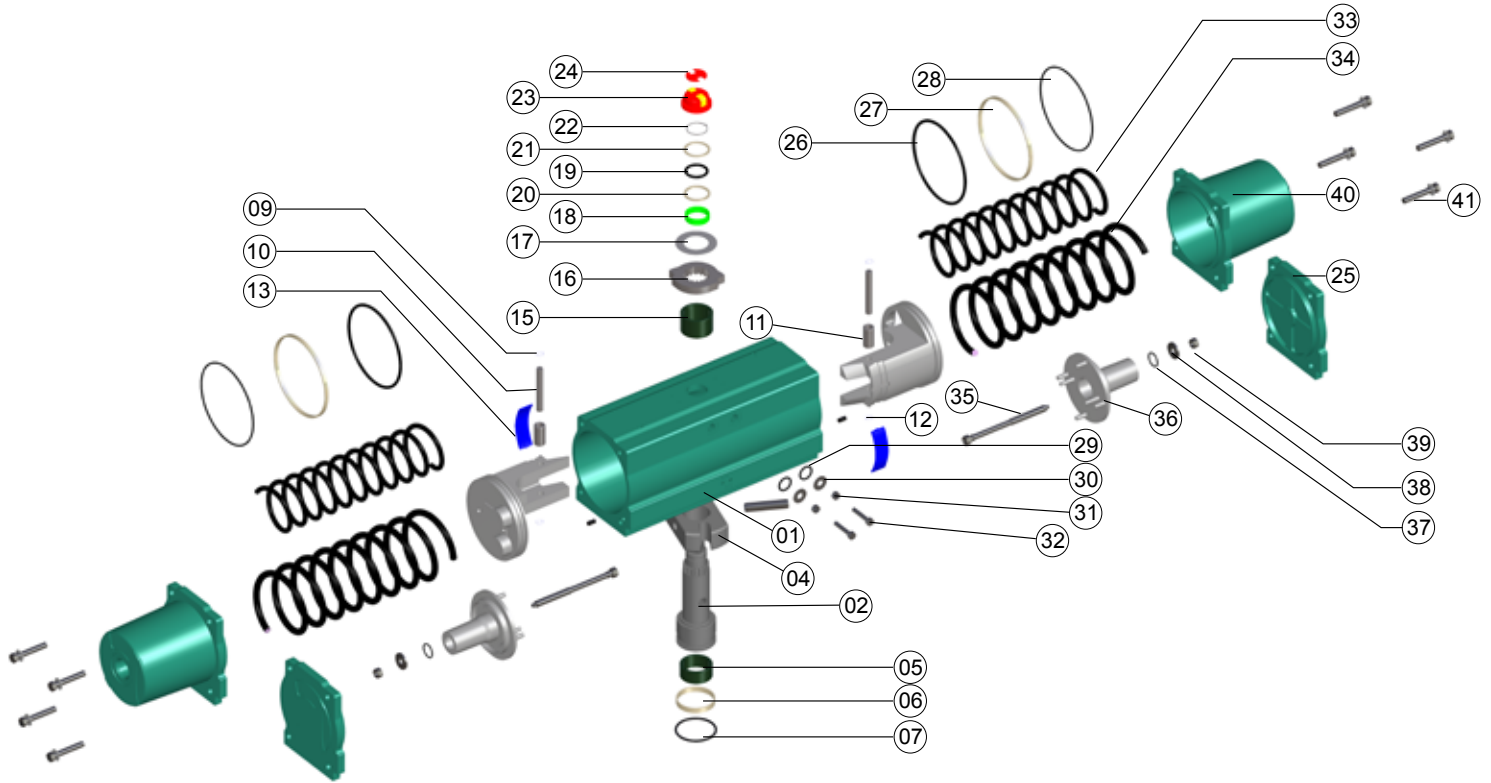

MATERIAL

NO	PART DESCRIPTION	Q'TY	MATERIAL
1	Cylinder Body	1	Aluminium alloy
2	Drive shaft	1	Steel alloy
3	Yoke Pin	1	Steel
4	Yoke	1	Steel
5	Bottom Spacer	1	Nylon
6	Stem Bottom Bearing	1	Stainless Steel
7	Stem Bottom O-Ring	1	NBP
8	Piston	2	Aluminium
9	Snap Ring	2	Stainless Steel
10	Roller Pin	1	Steel
11	Shaft	1	Steel
12	Snap Ring	2	Stainless Steel
13	Piston Back Bearing	3	PTFE
14	Hole Sealant	2	NBR
15	Top Spacer	1	Nylon
16	OCT Cam	1	Steel
17	Stem Thrust Bearing	1	Stainless Steel
18	Stem Top Bearing	1	Stainless Steel
19	Stem Top O-Ring	1	NBR
20	Teflon Washer	1	PTFE
21	Stem Thrust Washer	1	Stainless Steel

NO	PART DESCRIPTION	Q'TY	MATERIAL
22	Snap Ring	5	Stainless Steel
23	Indicator	1	ABS
24	Indicator Holder Cover	1	ABS
25	Double Acting Cover	2	Aluminium
26	Piston O-Ring	2	NBP
27	Bearing (piston head)	3	PTFE
28	Cover O-Ring	2	NBR
29	Stop Bolt O-Ring	2	NBR
30	Stop Bolt Washer	2	Stainless Steel
31	Stop Bolt Nut	2	Stainless Steel
32	Stop Bolt	2	Stainless Steel
33	Inner Spring	1 or 2	Spring Steel
34	Outer Spring	1 or 2	Spring Steel
35	Spring Bolt	1 or 2	Stainless Steel
36	Spring Retainer	1 or 2	Aluminium
37	Spring O-Ring	1 or 2	NBR
38	Spring Washer	1 or 2	Steel
39	Spring Nut	1 or 2	Stainless Steel
40	Spring Return Cover	2	Aluminium
41	Cover Bolt	8	Stainless Steel
42			



JDV  
CONTROL  
VALVES

# JMO Series

## Manual Override 手动装置



JMO Series manual override is an emergency device for opening/closing of valve in case of pneumatic actuator failure.its self-locking worm gear design provides safe and easy operation for transferring between control and manual.

JMO 系列手动装置为一款紧急操作装置，用物当气动执行器失去作用时，依然能即由手动装置来达到阀的开/关作用。特殊的过轮自动定位设计，使得在切换气动/手动过程中更为安全及简易。

APPLICABLE STANDARD 设计标准

Model 型号 : JMO-1/JMO-2/JMO-3/JMO-4

Torque Range 扭力范围 : 100 to 5200Nm

Temperature 温度范围 : -20°C to +80°C

Stroke Adjustment 角度调整范围 : ±10°C

Movement 作动范围 : 0° to 90°





## TECHNICAL SPECIFICATION 技术资料

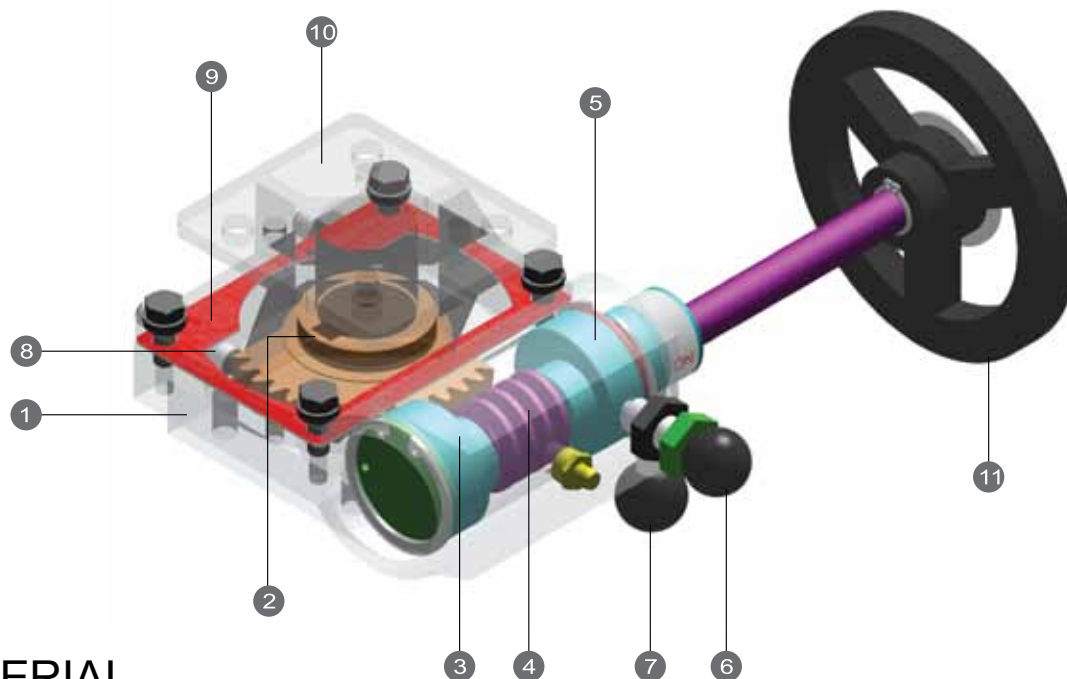

## MATERIAL

NO	PART NAME	MATERIAL
1	HOUSING	ALUMINUM
2	WORM WHEEL	IRON
3	ECCENTRIC BUSH BEAR	ALUMINUM
4	WORM SHAFT	ALUMINUM
5	ECCENTRIC BUSH H/W SIDE	ALUMINUM
6	SELECTOR	STEEL

NO	PART NAME	MATERIAL
1	ON/OFF LEVER	STEEL
2	LIMIT STOP	STEEL
3	GASKET	ASBESTOS
4	TOP COVER	ALUMINUM
5	HAND WHEEL	ALUMINUM
6	SELECTOR	STEEL





**JMO-1~JMO-3**

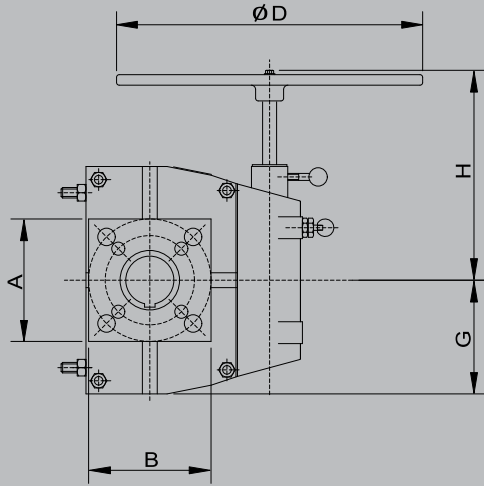

**BOTTOM PAD DETAILS**

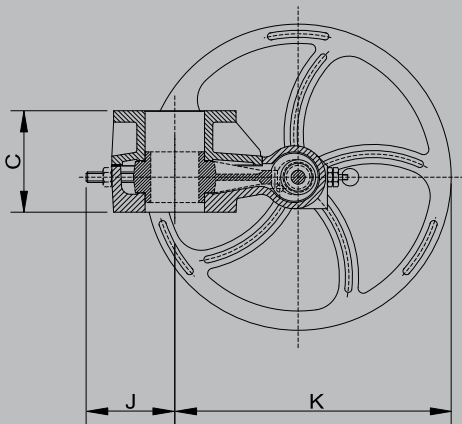
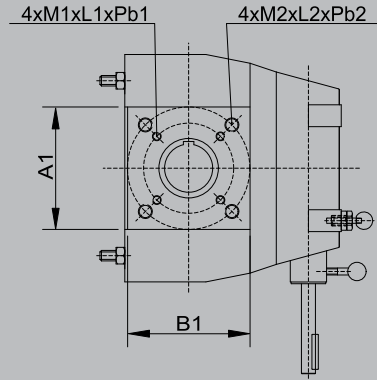

**SECTION - P-P'**

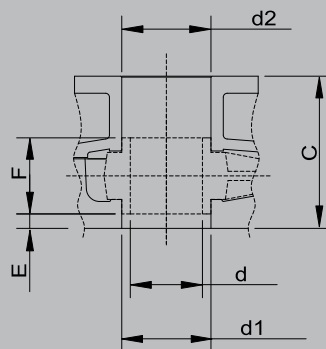

**DRIVE DETAILS.**

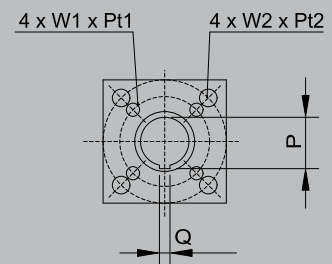

**TOP PAD DETAILS**

**DIMENSION**

MODEL	A	B	A1	B1	C	D	E	F	G	H	J	K	Ød	Ød1	Ød2	P	Q	WT (KG)
JMO-1	71.5	80	72	80	74	100	18.5	25	50	130	40	99-106	27	38	28	30.4	8	2
JMO-2	100	120	100	100	88	200	23	35.5	73	170	70	175-184	32	42.5	42.5	35.3	8	5
JMO-3	140	140	140	140	124	350	19	58	134	240	102	307-316	55	68	68	58.3	12	14
JMO-4	160	290	262	262	168.8	600	14	80	200	420	145	498-526	100	130	130	105.5	25	43

MODEL	M1xL1xPb1	M2xL2xPb2	WxPt1	WxPt1	NO. OF TURN	INPUT FORCE MAX (N)	OUTPUT TORQUE MAX (Nm)
JMO-1	M6x9 DEEPxPCD-50	M8x13 DEEPxPCD-70	Ø6.6xPCD-50	Ø9.0xPCD-70	9.5	82	100
JMO-2	M8x13 DEEPxPCD-70	M10x16 DEEPxPCD-102	Ø9.0xPCD-70	Ø11.0xPCD-102	10	400	500
JMO-3	M10x16 DEEPxPCD-102	M16x16 DEEPxPCD-140	Ø11.0xPCD-102	Ø18.0xPCD-140	20	400	1600
JMO-4	M20x22 DEEPxPCD-165	M16x17 DEEPxPCD-254	Ø17.0		22	400	5200

JMO-4

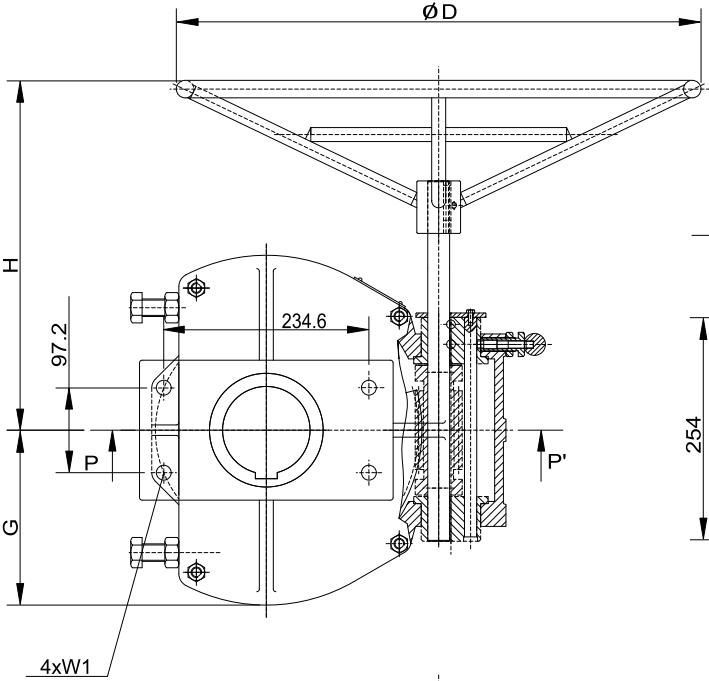

BOTTOM PAD DETAILS

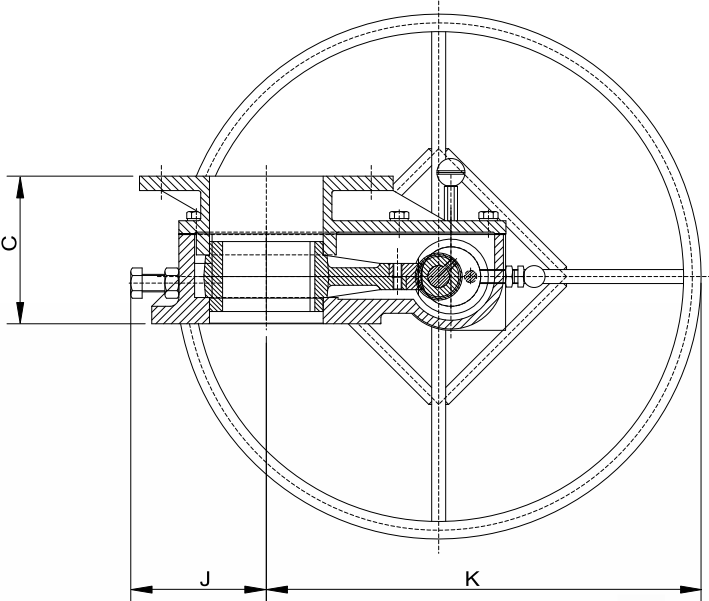
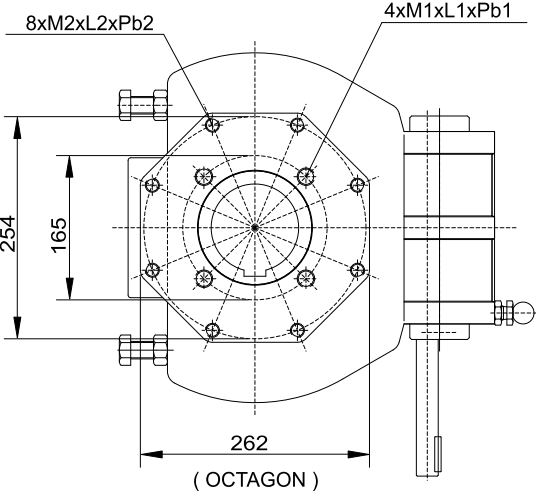

SECTION - P-P'

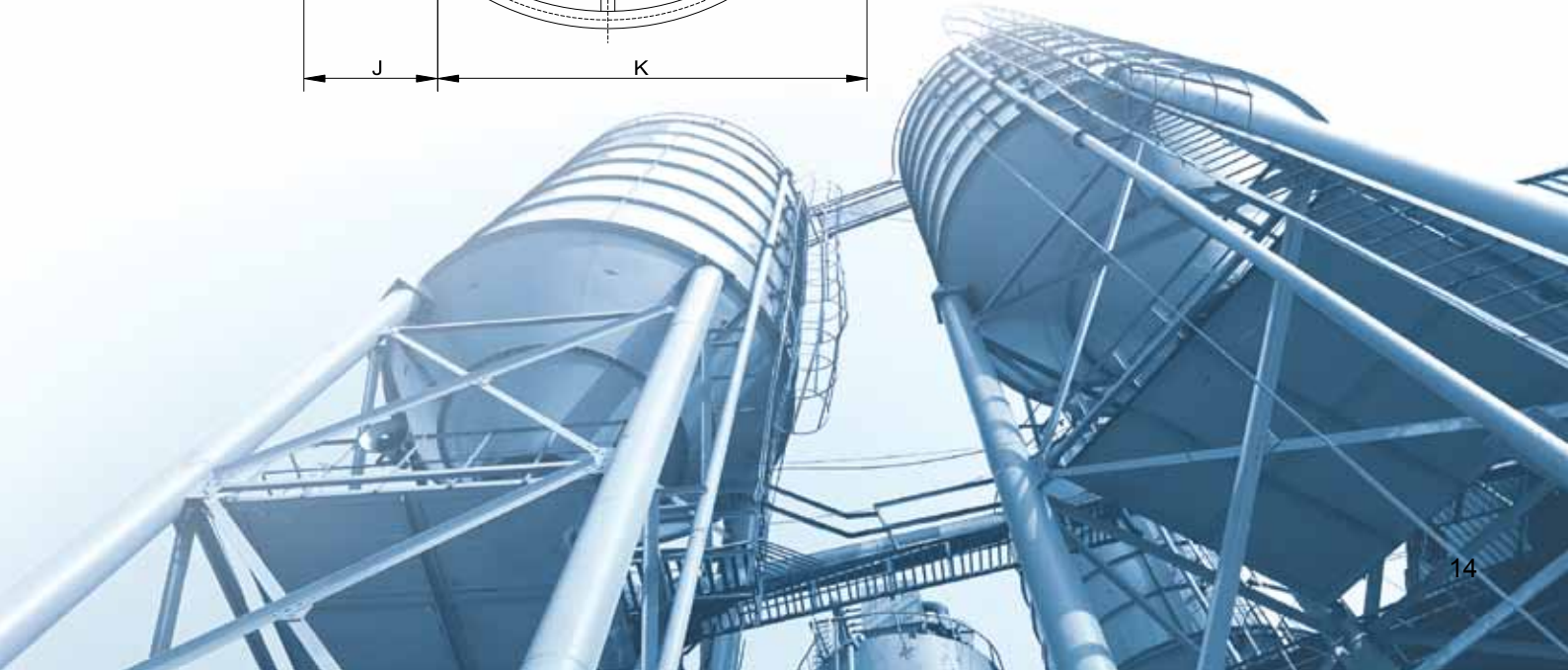



■ HEADQUARTERS

NO.6-1, QINGNIAN RD., YANGMEI DIST., TAOYUAN CITY 326, TAIWAN  
Tel: 886-3-4965066 Fax: 886-3-4965300 E-mail: sales@jdv.com.tw

Copyright 2009/12. All rights are reserved by JDV. Technical data and content may be changed by JDV as necessary



6D-0539



0575

